



**BINTELLI**

**(866) 542-8677**



**BINTELLI** **SERIES**  
**BEYOND** **LSV**

**BINTELLI BEYOND USER MANUAL**

[WWW.BINTELLIEV.COM](http://WWW.BINTELLIEV.COM)

# Chapter I Introduction

Thank you for choosing Bintelli Electric Vehicles. Your comfort and safety are very important to us, so we strongly recommend that you read and follow the operating instructions and safety procedures in this manual. To avoid serious personal injury, you must follow these operating instructions. We recommend that you ask any person operating this vehicle to read this manual before operating the vehicle.

Please read and understand the contents of this manual before operating the golf cart. Bintelli continually seeks advancements in product design and quality; therefore, while this manual contains the most current product information available at the time of printing, there may be minor discrepancies between your actual golf cart and this manual. If you have any questions about this manual, please contact us.

## Chapter II Security Statements

Always read this User's Manual in its entirety before attempting to drive or repair the vehicle. Failure to follow the instructions in this manual may result in property damage or serious injury.

Please pay attention to the important statements marked "Danger "," Warning "," Caution" in this manual and the warning signs displayed on the vehicle. If any operating or safety warning sign on the vehicle is damaged, peeling or blurred, it should be replaced immediately to prevent property damage, personal injury or death. Please contact Bintelli or an authorized Bintelli dealership if necessary.

This vehicle is limited to a certain number of passengers (including drivers). The number of passengers depends on the specific model

Do not operate this vehicle under the influence of alcohol and/or drugs that can impair vision and judgement.

Please do not drive on highways, as this is not permitted by law.

When operating this vehicle, keep your entire body inside the vehicle. Always remain seated and secured while the vehicle is in motion

Do not operate the vehicle until everyone is seated.

Keep your hands on the steering wheel and eyes on the road ahead while driving; take extra care when backing up in busy areas; do not start and brake suddenly; speed up or slow down according to the road conditions; when driving at high speed, do

not turn the steering wheel suddenly. Do not make any changes or additions to the safe operation and carrying capacity of this vehicle, or make any changes that are not in accordance with this manual.

## Danger

The batteries on your new vehicle are capable of delivering large levels of power that can cause injury and even death, observing safety rules is of paramount importance. For your safety, never smoke near the vehicle. Your vehicle should be stored away from sparks or flames. Only use the appropriate charger for your vehicle to ensure proper recharging. Only operate the vehicle in well ventilated open areas. When working on or near the battery, always wear eye protection, protective clothing and gloves.

Bintelli Electric Vehicles does not provide protection against lightning, flying objects or other storm-related hazards. If there is a storm when driving a Bintelli vehicle, you should leave the vehicle and take shelter from the rain in a place that meets the safety guidelines.

## When performing maintenance

Only trained technicians should service or repair the vehicle or battery charging system. Anyone doing even simple repairs or service should have knowledge and experience in electrical and mechanical repair. The appropriate care must be used when performing maintenance, service, or accessory installation.

Before disconnecting or connecting the batteries, the Tow/Run switch must be in the Tow position if your vehicle is equipped. Failure to comply with this warning may result in battery failure leading to serious personal injury.

When maintaining the vehicle or battery charger,

wear protective glasses or approved eye protection. When working on or near the battery, wear proper eye protection and insulative gloves.

Do not wear loose clothing or conductive jewelry such as rings, watches and bracelets.

Insulated tools shall be used when working near the battery or power connector. Always be careful to prevent short circuiting of components or wires.

Before working under the cart, be sure the parking pedal is in on, and put the "Tow (OFF)/ Run (ON)" switch in the "Tow" position and unplug the key to avoid injury.

Always operate in a safe environment and do not modify any safety measures.

Please keep a record of maintenance. Check these records regularly to ensure accurate and complete data entry.

Please keep all signs, warnings and instructions provided by the manufacturer clear and untampered.

## **Safe use plan**

Improper use or maintenance can cause damage to the vehicle.

This section includes all guidelines for the safety of the cart. Before the cart is used, the person operating the vehicle should be aware of all safety measures that are required.

These materials are intended for those responsible for the safety inspection of this vehicle, and if you are involved in the maintenance and operation of this vehicle, we strongly encourage you to follow these guidelines

### **Driver qualification:**

We recommend contacting your local DMV for rules and regulations regarding who may legally operate the vehicle

## **Safety Information**

### **Tip!**

Make sure the road is free and clear of any debris that could potentially cause accidents or damage to your cart or harm the occupants

Exercise caution in areas such as:

**Steep slopes:** Excessive slopes can overload the golf cart. Approach slopes directly, never at an angle to reduce the risk of rollover.

**Sharp bends, blind spots:** Approach sharp turns and blind spots with extra caution and lower your speed to pass safely.

**Soft ground:** Wet ground can cause the vehicle to lose traction and stability, adjust your speed accordingly to the conditions

## **Maintenance of vehicle safety:**

**Maintenance:** Please check regularly according to the manufacturer's instruction to ensure that the driver can operate the cart comfortably and safely.

**Personnel:** Only trained and authorized personnel can inspect, adjust and maintain the vehicle.

**Parts and Materials:** Only parts and materials coming from the manufacturer should be used

## Chapter III Controls and Indicators

### Tip!

Always ensure that any and all drivers are familiar with all controls and operating procedures before driving the vehicle.

Do not switch the "Forward (F)/ Reverse (R)" switch when the vehicle is moving. Doing so will damage the vehicle and could lead to personal injury. To avoid injury to passengers or damage to the vehicle, always perform a complete stop before switching the "Forward (F)/ Reverse (R)" switch.

When coming to a stop, always release the accelerator pedal completely before applying the brake. Apply firm consistent pressure with the brake pedal until the vehicle stops. Before exiting the vehicle, always apply the parking brake. To turn the vehicle off, switch the "forward (F)/reverse (R)" switch in the "neutral (○)" position, turn the key switch to the "OFF " position and remove the key. If your vehicle is equipped with an electronic key, remove the electronic key from the key card slot.

Instrument display

Key switch

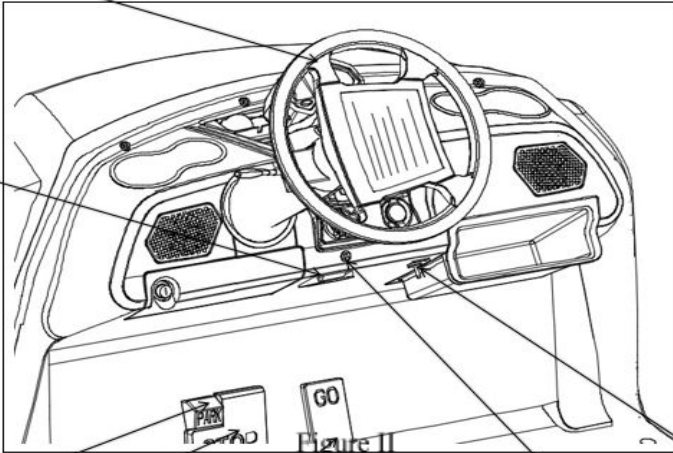

Parking pedal Brake pedal Accelerator pedal Hazard light switch Tow / Run switch

SOC

Speedometer

High beam light

Low beam light

Left turn signal

Right turn signal

Parking indicator

Brake fluid indicator

Low voltage indicator

Fault code

Odometer

Motor failure indicator

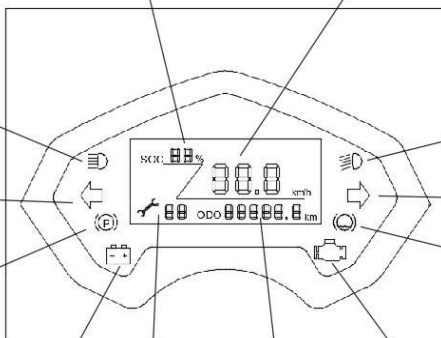



### **Mechanical key switch:**

The key switch is located on the dashboard below the steering wheel (Figure 1). The switch has 2 positions. OFF and ON which are clearly marked.

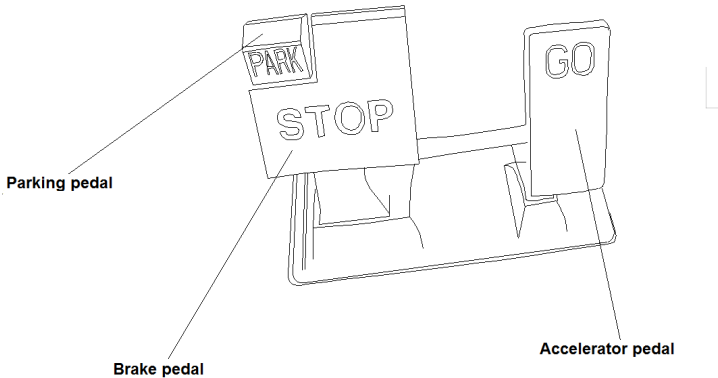

Figure V

Note: the key can only be removed when the key switch is in the OFF position.

### **"Forward (F)/ Reverse (R)" control**

The "Forward (F)/Reverse (R)" switch is located on the front panel of seat (Figure 2). Forward (F)/Reverse (R) positions are clearly marked. When the switch is pressed to the F( forward) position, the vehicle will move forward, and when the switch is pressed to the R(reverse) position, the vehicle will move backward. While in reverse, the buzzer will sound a warning tone. When the switch is in the "Neutral" position, the vehicle will not accelerate forward or backward, even if the acceleration pedal is pressed.

### **Accelerator pedal**

Accelerator pedal is located on the right side with the mark "GO " (Figure 5.) .When the key switch is in

the "ON" position and the "Forward (F) / Reverse (R)" switch is not in neutral (○). The vehicle can go forward or backward. As the accelerator pedal is gradually pressed, the speed will increase until full speed is reached. After releasing the accelerator pedal, power to the motor will cease and the vehicle will decelerate.

### **Brake pedal**

Brake pedal is located on the left side with the mark "STOP" (Figure 5). To slow or stop the vehicle, press the pedal.

### **Parking brake pedal (Vehicles with DC Motor)**

The parking pedal is in the upper left corner of the brake pedal, with mark "PARK" (Figure 4). It is used to prevent the vehicle from moving when the driver leaves the vehicle.

### **Tip!**

The parking pedal will be released when the accelerator pedal or brake pedal is pressed.

### **Electromagnetic parking brake (Vehicles with AC Motor)**

When the vehicle is stationary, electromagnetic parking starts automatically and the vehicle will stop moving. When the vehicle is in "Forward (F)" or "Reverse (R)", stepping on the accelerator pedal will cause the electromagnetic parking to be automatically released.

### **Instrument display**

As shown in figure 4, it is used to display the real-time status of the vehicle.

1. Real-time status of charge will show the

vehicle's battery information, when the power is less than 30%, the vehicle needs to be recharged.

2. The low beam icon will light up when the vehicle is in the low beam mode.

3. The high beam icon will light up when the vehicle is in the high beam mode.

4. The left turn signal icon will blink when the left turn signal is on.

6. The right turn signal icon will blink when the right turn signal is on.

7. When the vehicle is in the parked position, the parking lights will be on.

8. Speedometer will show the current speed of the vehicle.

9. When there is a malfunction in the vehicle, a fault code will be displayed on the instrument cluster. Contact your local service center to have them diagnose the cause for the fault code and stop using the vehicle.

10. When the vehicle has low voltage, the battery fault light will be on indicating the batteries need to be charged immediately.

11. When an error is detected, the motor failure indicator will light up.

12. When the brake fluid is low, the brake fluid level indicator will light up.

13. The number on the odometer is the current total mileage of the vehicle.

## **Multifunctional speaker system**

### **Bluetooth instruction**

Make sure your phone's Bluetooth is on and available to pair, search for the Bluetooth device name "Beyond", and press MOD to match or connect. There will be a Bluetooth icon next to the successfully connected Bluetooth device.. The BT AUD mode will

be displayed in MOD mode if the match is successful. In BT AUD mode, users can press the volume buttons to play music, answer a call or press END button to hang up the phone.

### **Tow/Run switch**

Located on the lower right side and on the left side of the glove box (Figure 1).

Before driving the vehicle, you must turn the switch in the "Run (ON)" position. When the switch is turned to "Tow (OFF)" , the power supply will be cut off and the vehicle will not turn on.

**Before towing the vehicle:** To tow the vehicle safely and deactivate the electronic parking brake, you may turn off all motor braking functions with the "Tow (OFF)/Run(ON)" switch in the "Tow (OFF)" position. This will prevent damage to the vehicle or electrical parts.

Before disconnecting and connecting the battery cables: Turn the "Tow (OFF)/Run (ON)" switch in the "Tow (OFF)" position and shut down the power supply to the electrical system of the vehicle. This prevents electrical arcing or possible battery failure when the battery cable is disconnected.

Wait 10 seconds when you need to switch between "Tow (OFF)" or "Run (ON)".

For long-term storage, please turn the "Tow (OFF)/Run (ON)" switch to "Tow (OFF)" position to limit the rate of battery discharge.

### **Combination switch**

Located on the left side of the steering column (Figure 1).

Horn switch: Press the front end of the handle of

the combination switch to activate the horn.

Low beam light switch: Pull the switch backward. The low beam light will be activated and the low beam light icon on the instrument will light up.

High beam light switch: Push the switch forward. The high beam light will be activated and the high beam light icon on the instrument will light up.

Left turn signal light switch: Press the switch downward. The left turn signal light will be activated and the left turn signal light icon on the instrument will light up.

Right turn light: Push the switch upward. The right turn signal light will be activated and the right turn signal light icon on the instrument will light up.

## Chapter IV Identification

### VIN or Serial number of vehicle

Vehicle Identification Number (VIN) is located on the front panel of the first row of seats if equipped.

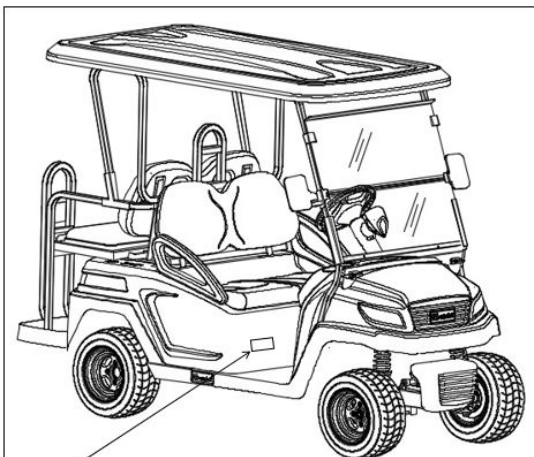

VIN Plate

Figure VI

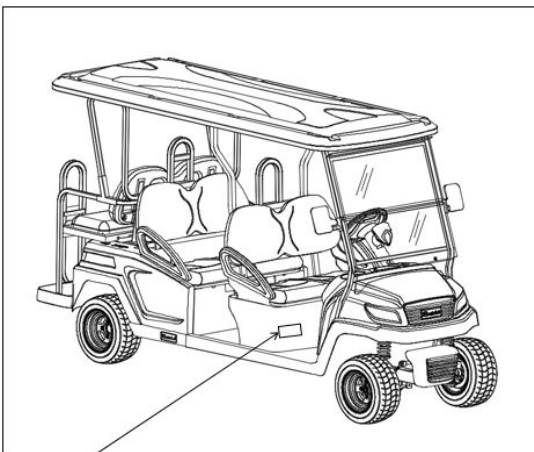

VIN Plate

## Chapter V Before operation

As with any new vehicle, always familiarize yourself with its controls, indicators and operations. Prior to driving the vehicle, follow the guidelines below to ensure proper operation.

Use the following as a guide when inspecting the vehicle. Always check the working condition of the vehicle daily and perform routine maintenance.

### Warning:

Always ensure that the key is removed before performing the following checks. Also ensure that the parking brake is on if the vehicle is equipped with a manual parking brake.

### Checklist before operation:

Check the following before each use:

#### Batteries:

Check the batteries are securely fixed into the vehicle and all cables are tightened to specifications. Ensure the battery covers are securely in place with no fluid leaks. Ensure the vehicle has been properly charged and is ready for use.

#### Tires:

Recommended tire pressure is 30 psi.

Check the tire surface for damage, cracks and any foreign objects. Replace the tire immediately when the tire pattern is worn to less than 0.04 inches (1 mm).

## **Body and chassis**

Inspect the body and chassis for damage or missing items before each use.

## **Daily checklist:**

Please use the following checklist as a guide to check the vehicle and its working condition.

## **"Forward (F)/Reverse (R)" control:**

Check for proper operation.

## **Tip!**

When switched to Reverse (R), the buzzer will start beeping regardless of whether the vehicle is on or off as a safety feature.

## **Brakes:**

Ensure the brakes works properly. When appropriate pressure is applied on the brake pedal, the brake pedal should not reach the floor mat, and the vehicle should stop smoothly within reasonable distances. If not, please check the brake system and make necessary adjustments or contact your local service center for maintenance.

## **Parking brakes:**

If equipped, when the parking brake pedal is pressed into the parking position, the vehicle will remain stationary (incline of up to 20%). When the accelerator pedal or the brake pedal is pressed, the parking brake pedal will be released automatically .

## **Reverse buzzer:**



When the "Forward (F)/Reverse (R)" switch is in the "reverse (R)" position, the reverse buzzer will start beeping.

**Steering:**

The vehicle should be easy to steer and the steering wheel should not turn automatically.

Check the steering system for excessive play by moving the steering wheel up, down, back and forward.

Turn the steering wheel gently to the left and right.

If excessive play is found, or a noise is heard, maintenance may be required.

## Chapter VI Vehicle Operation

Learn and familiarize yourself with all of the the controls prior to first use.

Make sure all passengers are seated and hold onto the armrests.

Read the safety warnings on the dashboard and pedals.

Turn the key to "ON". If it is an electronic key, insert the electronic key into the key slot. Once in the "ON" position, the instrument cluster will light up.

Place the vehicle into either forward or reverse via the "Forward (F)/ Reverse (R)" switch to select the driving direction.

To accelerate, slowly press the accelerator pedal and the parking pedal will be automatically released if equipped with the electronic parking brake. The vehicle will begin to move. As the accelerator pedal is gradually pressed down, the speed will increase until full speed has been reached.

### TIP!

When going downhill, monitor your speed.

Always slow the vehicle down on declines and sharp turns to maintain control of the vehicle.

Note: if the "forward (F)/Reverse (R)" switch is switched to "neutral (○)", the vehicle will not be able to accelerate.

**Parking the vehicle:**

After reaching your destination the parking brake pedal should be firmly pressed down until it is in position if your vehicle is so equipped. This will prevent the vehicle from rolling unexpectedly.

Once stationary and parked, turn the key switch to the "OFF". If it is an electronic key please remove the electronic key from the key card slot." Forward (F)/ Reverse (R)" switch should then be toggled to the "neutral (○)" position. Always remove the key when the vehicle is not in use.

**Tip!**

It is normal for new vehicles to not reach maximum driving range until after multiple charging cycles. This is perfectly normal, so always ensure your vehicle is being charged correctly by plugging directly into a 20 amp dedicated 110V circuit. Use of extension cords, improper amperage circuits or non original manufacturer equipment can harm the batteries and void your warranty.

## Chapter VII Storing the Vehicle

If the vehicle needs to be stored for an extended period of time, perform the following actions;  
Turn the "Tow (OFF)/Run (ON)" switch to "Tow (OFF)".  
Remove the key and keep it in a safe place.  
Ensure each tire pressure reading is 30PSI.  
Verify each battery is filled to the proper level with distilled water and all cable connections are secure.  
Clean the body, seat, battery box, and chassis.  
If storing outdoors, cover the vehicle.  
Plug in the onboard smart charger and leave plugged in.  
Check the battery water level at least once a month.  
Regularly lubricate every six months.  
Monitor the battery connections and cables for corrosion, remove with soda water if necessary.  
Do not use the parking brake. Instead, use a block or wheel stop to prevent movement of the vehicle.

### Tip!

When the temperature where the vehicle is stored reaches higher than 95°F or 32°F C, check the specific gravity of the battery every 2 to 4 weeks. Always charge the batteries, when the state of charge (SOC) reaches 70%.

At temperatures lower than 32°F or 0°F C, always keep the batteries fully charged to prevent solidification which can decrease the service life of your batteries.

# Chapter VIII Maintenance

## Regular Maintenance Check List

Regular maintenance is necessary for best performance and safe operation.

**Always ensure that the Tow (OFF)/ Run (ON)" switch is in OFF position before performing any vehicle maintenance.**

C=CHECK; CA=Check & Adjust; R= Replace; S= Perform; CL= Clean & Lubricate; L= Lubricate							
N o.	Items	Before Use	Every month/ 20 hours/ 100 miles	Every 6 months/ 125 hours/600 miles	Every year/ 250 hours/ 1200 miles	Every 2 years/ 500 hours/ 2500 miles	Every 4 years/ 1000 hours/ 5000 miles
1	Battery Charge	S	S	S	S	S	S
2	Clean the batteries/ inspect connections	S	S	S	S	S	S
3	Check brakes	C	CA	CA	CA	CA	CA
4	Check Steering System	C	C	C	C	C	C
5	Check tire pressure, tread	C	CA	CA	CA	CA	CA

6	Check body and chassis	C	C	C	C	C	C
7	Check body hardware	C	C	C	C	C	C
8	Check reverse signal	C	C	C	C	C	C
9	Check battery fluid level		C	C	C	C	C
10	Check body panels		C	C	C	C	C
11	Clean and lubricate pedals		CL				
12	Check seats for cracks or damage			C	C	C	C
13	Check shock absorbers			C	C	C	C
14	Battery discharge test				S	S	S

15	Clean battery terminals				S	S	S
16	Check thickness of brake shoes and rear axle		C	C	C	C	C
17	Check steering wheel freeplay			CA	CA	CA	CA
18	Check tightness of wheel lugnuts and front wheel bearings				C	C	C
19	Check the level and condition of axle fluid				C	C	C
20	Check and adjust brakes				CA	CA	CA
21	Replace rear axle lubricant				R	R	R
22	Check rear axle						CA

## Battery maintenance

### Danger:

The fluid in the batteries is toxic and proper care should be taken when working on or near the batteries. The fluid in the batteries contains sulfuric acid and caution must be taken to prevent any contact with bare skin, eyes, or clothing. Always wear appropriate protection!

### Always

- Always wear protective clothing, gloves and safety goggles
- Always use insulated tools when working on batteries
- Always check connections for proper torque
- Always keep sparks and flames away from batteries
- Always ensure plates are covered in distilled water before charging
- Always use the provided on-board smart charger to charge batteries
- Always neutralize small spills with baking soda and water. For large spills, contact the appropriate first responders.

### NEVER

- Never smoke near batteries
- Never wear jewelry or metallic objects when working on/around batteries
- Never make direct contact with the acid in the batteries. If contact occurs flush with large amounts of water
- Never place objects on top of batteries
- Never add acid to a battery



- Never charge a frozen battery
- Never charge a battery with temperatures above 122F (50C)
- Never Store batteries unless fully charged
- Never leave an acid spill unattended.

Proper maintenance and charging will lead to optimum performance and battery life.

### **How to maintain batteries**

Clean the battery terminals and connections with baking soda and water to prevent and clean corrosion.

Before you charge: Add distilled water until the plates are fully submersed.

For in depth battery maintenance please consult the battery information included in your purchase packet.

### **Caution:**

Add distilled water only. Ordinary water contains minerals, which is harmful to the battery.

Please use a hydrometer to check the traction of battery liquid and make a comparison according to the attached table. If the reading is low, please contact your agent.

The specific gravity of TROJAN battery is shown in the table below. For other battery types consult the battery manufacturer for accurate information.

SOC	specific gravity
100%	1.277
90%	1.258
80%	1.238
70%	1.217
60%	1.195
50%	1.172
40%	1.148
30%	1.124
20%	1.098
10%	1.073

### **Battery charging**

#### **Warning:**

Before charging the vehicle, please read and understand the charger manual.

#### **Warning:**

While batteries are charging, hydrogen will be released. Only charge batteries in a well-ventilated area.

Always follow the instructions in the charger manual to charge the batteries.

The following is a summary of the charging steps. Do not try to charge the vehicle without reading and fully understanding the guidelines in the manual.

The onboard charger has a built on charging cord that plugs directly into a standard 110V outlet. Only use dedicated 20amp circuits when charging the vehicle, failure to do so will cause improper charging that will negatively affect the vehicle range and service life of the batteries. When in doubt, contact a local electrician to inspect the outlet in question.

### Caution;

Use only the charger specific to the vehicle. Never use a battery tender. Failure to use anything other than the original equipment charger can result in vehicle damage.

When batteries are fully charged, the charger will shut down automatically.

### Battery Layout

### Danger:

When installing batteries, Never touch or bridge both poles with metal tools as this can cause severe damage and even battery explosion.

Batteries are installed in the vehicle as shown below:

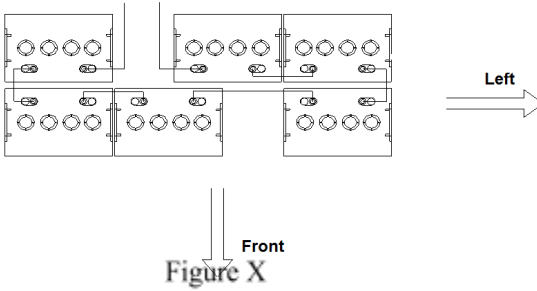

## Warning:

When installing batteries, be careful to ensure the cables do not touch other batteries accidentally.

Always remove the negative power cable (-) of the main cable first and install it last.

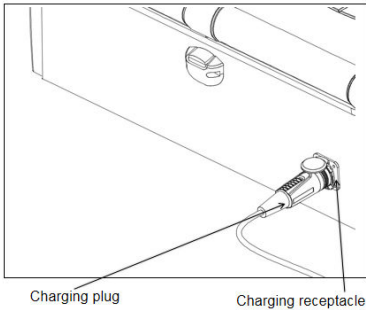

Figure XI

## Caution:

Do not overtighten battery cable connection hardware. Always use the appropriate torque specifications included in the manual.

### Transaxle maintenance

Follow the maintenance intervals as recommended and visually inspect for leaks before use.

### Fluid check

Park the vehicle on a level surface.

Remove the access panel.

Remove gear box filler cap.

Add oil until the liquid level reaches the hole.

Reinstall the cap.

Recommended lubricating oil:

**SAE 90** Gear oil

Gear box capacity:

**0.3L**

Note: It is always recommended to have your local dealership or service center perform transaxle maintenance.

## General Maintenance

### Warning:

Always ensure the Tow (ON)/ RUN (OFF) switch is off before performing any maintenance on the tires or brakes.

### Changing tires

Make sure the vehicle is parked on a level surface. Lift the vehicle with the appropriate rated jack directly on the frame itself. Never lift the vehicle from the body or suspension, as that can damage the vehicle. Remove the lug nuts and pull the wheel directly off the vehicle. When installing, reverse the procedure.

### Brake adjustment

1. Before adjusting the brakes, press the brake pedal several times to make sure proper pressure is built up. If the brakes are not functioning properly or the pedal loses pressures as you depress it, do not use the vehicle and contact your local service center for maintenance.
2. To adjust the travel of the pedal, lift the floor mat and remove the square access cover. With very light pressure, press the pedal lightly to calculate the distance until pressure can be felt. Check for the travel to be between 20 and 30 mm.
3. If adjustment is required, loosen the nut and turn the nut outward or inward until it meets the requirement. Be sure to tighten the nut once complete.

## TIP!

Never over tighten the brake cable as this will reduce braking performance.

If you suspect a problem with the brakes, contact your local service center or dealership. Brake failure can cause serious injury